



CMC 25 Arbor Pro

Built for the Tree Professional



Safer, non-slip outrigger pads



New arborist saw holder



The Heavy Duty Lift, the CMC 25 Arbor Pro (now available with safer, non-slip outrigger pads and a new arborist saw holder) is a self-propelled tracked aerial platform built for one of the roughest industries on this planet - the tree industry. Equipped with many exceptional time saving features, this reliable 25 metre working height lift has an impressive 14 metre outreach. With incredibly compact dimensions, this serious aerial work platform is capable of BIG performance.

Designed with 1 articulating/1 telescopic lower boom and 1 articulating/2 telescopic upper booms, plus articulating jib on the end. This combination allows for best work maneuverability and outreach. A quick release 180° rotating basket with triple safety locks, rounds out this great lift that is a pleasure to work with.

Standard basket size is 1.70 m wide. Other smaller basket sizes are also available to best fit your application. The CMC 25 Arbor Pro comes equipped standard with two stabilisation areas and 6 possible outrigger configurations. With incredibly compact dimensions this serious aerial work platform is capable of entering virtually any door. Quiet diesel engine/240v electric hydraulic power pack is standard. Also available with hybrid power source.

CMC 25 ARBOR PRO COMPACT LIFT



Standard Specification

Max. working height	25 metres
Max. horizontal outreach	14 metres
Max. platform capacity	230kgs
Platform basket	Detachable aluminium - 1200x700x1100mm
Boom rotation	360 degrees
Stabiliser base area	5.9m x 4.4m
Boom configuration	1 articulating/1 telescopic lower boom 1 articulating/2 telescopic upper boom Articulating jib

Minimum closed length	6062mm
Minimum closed width	877mm
Minimum closed height	1971mm
Gross weight	3800kgs

Engine	Kubota Diesel
AC motor	240v 15amp 2.2kW

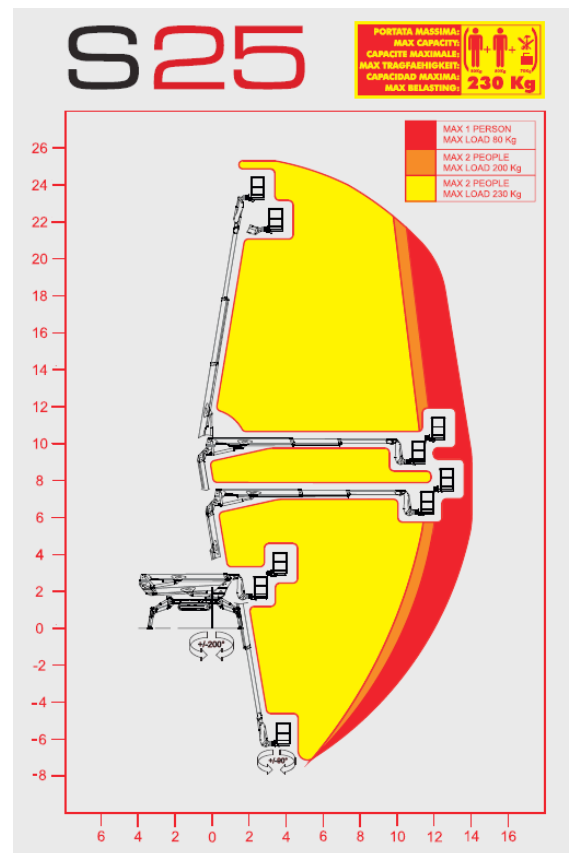
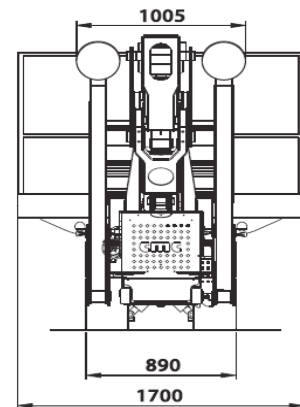
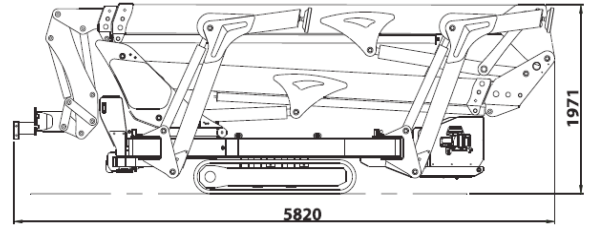
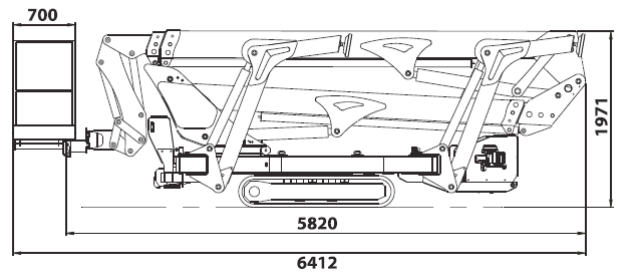

📞 1300 072 926

VIC 24-28 Williams Road Dandenong Sth. 3175
F (03) 9791 7676
E vic@globalmachinerysales.com.au

www.cmclifts.com.au
www.globalmachinerysales.com.au

NSW Unit 1/21 Penny Place Arndell Park 2148
F (02) 8678 2478
E nsw@globalmachinerysales.com.au